



# CoaXPress Series

3 MP Color Camera

# KC300XC3CX

 Anti-vibration

 Anti-shock



## Anti-vibration imaging Camera

This product is an industrial camera equipped with a **global shutter**, **CMOS image sensor** and **CoaXPress interface**.

### Applicable Standards

Vibration test 10G : pass

Shock test 75G : pass

Anti-vibration: IEC60068-2-6(JIS C60068-2-6)

Anti-shock: MIL-STD-810H

### Features

- C mount Camera
- High performance and high quality
- Extensive know-how and solid technical capabilities

### Applications

- Inspection
- Measurement
- Character recognition
- Robot vision

### Recommend Lenses Series



*Kowa Optimed Deutschland GmbH*

## Specifications

Feature	Description
Monochrome / Color	Color
Interface	CXP-6
Sensor	IMX252
Sensor size	1/1.8"
Resolution	2064(H) x 1544(V)
Pixel size (μm)	3.45(H) x 3.45(V)
Electronic shutter	Global Shutter
Frames per second	149 fps
Power supply	PoCXP
Power consumption	Less than 3.6W
Operating temperature	0°C - +35°C (No condensation) ※Appropriate heat radiation is required
Operating humidity	20% - 80%RH (No condensation)
Storage temperature	-30°C - +60°C (No condensation)
Storage humidity	20% - 90%RH (No condensation)
Operational vibration	10G
Operational shock	75G
Dimensions (mm)	29(W) x 29(H) x 37(D) (Excluding Projections)
Lens mount	C mount
Weight (without lens)	Approx. 50g

## Dimensions

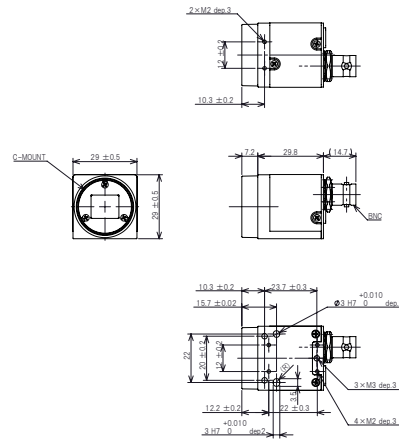

## Spectral response and quantum efficiency

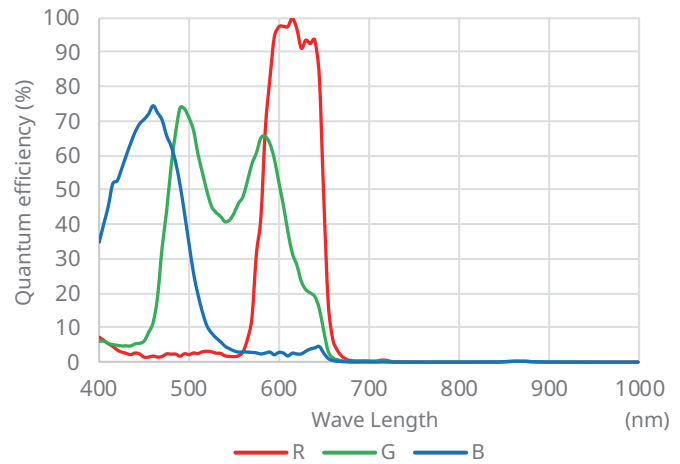

## Connector pin assignment

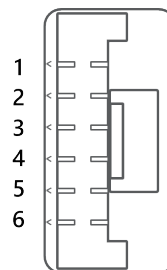

1. GPO A
2. GPO B
3. GPO C
4. PWM
5. GND
6. DC+24V



Kowa Optimed Deutschland GmbH

Please feel free to contact our team with any questions or further enquiries at  
[vision@kowaoptimed.com](mailto:vision@kowaoptimed.com)  
 we will be happy to provide assistance and consultation.

Fichtenstr. 123, 40233 Duesseldorf, Germany  
 TEL: +49-(0)211-542184-0  
[www.kowa-lenses.com](http://www.kowa-lenses.com)

Kowa Optronics Co., Ltd.

2F Kudan Center Bldg. 4-1-7, Kudan-Kita,  
 Chiyoda-Ku, Tokyo, Japan  
 TEL: 03-5651-7050

6-29, Nishiki 3-chome, Naka-ku,  
 Nagoya, Aichi, Japan  
 TEL: 052-963-393