



Harsh environmental resistance **GigE Vision** Series

8 MP Color Camera

KC800GC3CX

 Anti-vibration

 Anti-shock

 Oilproof

 Dustproof

 Waterproof



Waterproof, dustproof, oilproof, shock and vibration-resistant imaging Camera

This product is an industrial camera equipped with a **global shutter**, **CMOS image sensor** and **GigE interface**.

Applicable Standards

Vibration test 10G : pass

Shock test 75G : pass

Anti-vibration: IEC60068-2-6(JIS C60068-2-6)

Anti-shock: MIL-STD-810H

Features

- C mount Camera
- High performance and high quality
- Extensive know-how and solid technical capabilities

Applications

- Inspection
- Measurement
- Robot vision
- Food, Pharmaceuticals

Recommend Lenses Series



JC10M



Kowa Optimed Deutschland GmbH

Specifications

Feature	Description
Monochrome / Color	Color
Interface	GigE Vision
Sensor	IMX546
Sensor size	2/3"
Resolution	2856(H) x 2848(V)
Pixel size (μm)	2.74(H) x 2.74(V)
Electronic shutter	Global Shutter
Frames per second	13fps
Power supply	PoE or DC24V
Power consumption	Less than 6W
Operating temperature	0°C - +45°C (No condensation) ※Appropriate heat radiation is required
Operating humidity	20% - 80%RH (No condensation)
Storage temperature	-30°C - +60°C (No condensation)
Storage humidity	20% - 90%RH (No condensation)
Operational vibration	10G
Operational shock	75G
Dimensions (mm)	45(W) x 45(H) x 38(D) (Excluding Projections)
Lens mount	C mount
Weight (without lens)	Approx. 140g
Environment	IP67, Oil proof

Dimensions

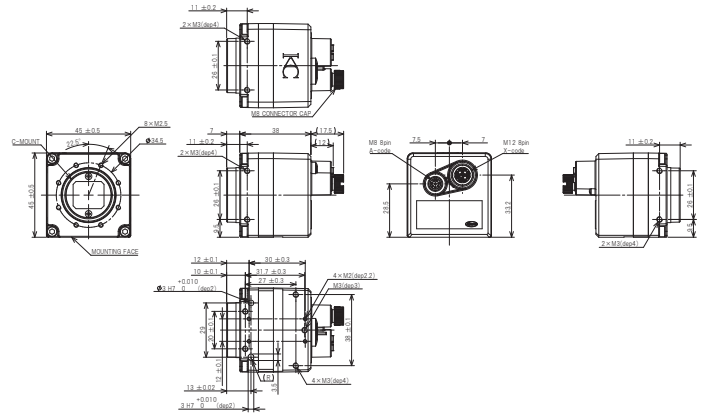

Spectral response and quantum efficiency

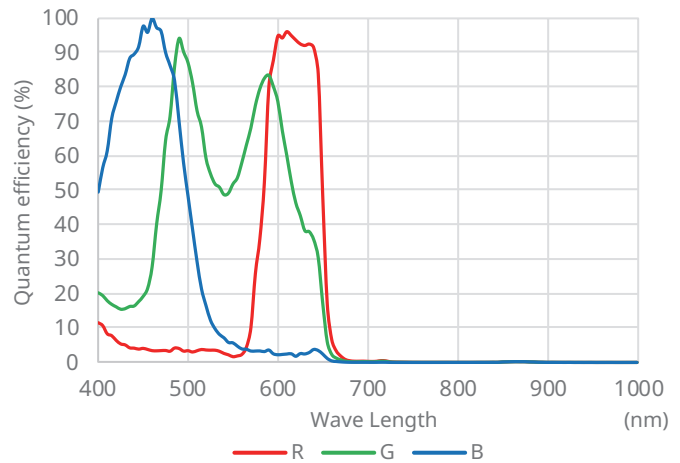

Connector pin assignment

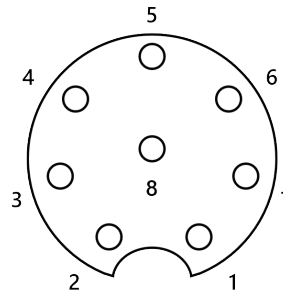

1. GPO A
2. GPO B
3. GPO C
4. PWM
5. N/A
6. N/A
7. GND
8. DC+24V



Kowa Optimed Deutschland GmbH

Please feel free to contact our team with any questions or further enquiries at
vision@kowaoptimed.com
 we will be happy to provide assistance and consultation.

Fichtenstr. 123, 40233 Duesseldorf, Germany
 TEL: +49-(0)211-542184-0
www.kowa-lenses.com

Kowa Optronics Co., Ltd.

2F Kudan Center Bldg. 4-1-7, Kudan-Kita,
 Chiyoda-Ku, Tokyo, Japan
 TEL : 03-5651-7050

6-29, Nishiki 3-chome, Naka-ku,
 Nagoya, Aichi, Japan
 TEL : 052-963-393